

# Cryogel® Z

## Installation Manual **PIPE INSULATION FOR COLD SERVICE**



**Contents**

(Click below to jump to section)

<b>Safety First</b>	<b>3</b>
<b>Material Handling</b>	<b>3</b>
<b>Preparation and Storage</b>	<b>4</b>
<b>Optimal Work Setup</b>	<b>5</b>
<b>Cold Installation Overview</b>	<b>6</b>
<b>Single Layer Installation</b>	<b>10</b>
<b>Single Piece Multi-Wrap Installation</b>	<b>11</b>
<b>Multi-Layer Installation</b>	<b>12</b>
<b>Small Bore Pipe</b>	<b>13</b>
<b>Pipe Fittings</b>	<b>14</b>
<b>45- and 90-Degree Elbows</b>	<b>15</b>
<b>Valves and Flanges</b>	<b>20</b>
<b>Filling Cracks and Voids</b>	<b>22</b>
<b>Cutting Charts</b>	<b>23</b>
Cryogel® Z 5 mm Blanket Cut Chart (cm)	23
Cryogel® Z 5 mm (0.2 in) Blanket Cut Chart (inches)	24
Cryogel® Z 10 mm Blanket Cut Chart (cm)	25
Cryogel® Z 10 mm (0.4 in) Blanket Cut Chart (inches)	26
Cryogel® Z Insulation Cladding Cut Chart (cm)	27
Cryogel® Z Insulation Cladding Cut Chart (inches)	28
Cryogel® Z Miter Cut Chart (mm)	29
Cryogel® Z Miter Cut Chart (inches)	31
<b>Appendix A: Materials/Accessory Suppliers</b>	<b>33</b>

Aspen Aerogels® recognizes that performance of our state-of-the-art Cryogel® Z insulation materials depends on the total thermal integrity of our system. Therefore, we have developed recommended guidelines for installing Cryogel® Z flexible insulation.

All of the procedures described in this manual have been field-proven in conjunction with installation partners.

We are constantly striving to develop new application procedures and insulation systems to make our products stand above our competition with quicker delivery times, simpler logistics, and more reliable installation.

We stand behind our products and are willing to work with you to develop application procedures to suit your project-specific execution plan.

For specialized training or recommendations regarding our application procedures, call 508-691-1111, visit [info.aerogel.com/contact](http://info.aerogel.com/contact), or scan below with mobile device QR reader.



**Contact Us**

#### Safety First

Cryogel® Z materials are engineered with safety and performance as our top priorities. Aspen has performed extensive EH&S testing and found our materials to be safe. Our Cryogel® Z insulation products are made of synthetic amorphous silica impregnated into a non-woven flexible fabric substrate. Synthetic amorphous silica is not considered to be a health hazard and, according to the U.S. EPA, “there should be no concerns for human health.” The silica used in our products is produced synthetically, not mined, and as such contains no crystalline silica.

Handling of Cryogel® Z blankets will produce dust. Workplace exposure to all dusts should be controlled with standard industrial hygiene practices. Cryogel® Z dust exposure may produce a sensation of dryness to skin and irritation to eyes, skin, and respiratory track. For worker comfort when working with Cryogel® Z, we recommend the use of dust masks, safety eyewear, and work gloves. Cryogel® Z dust can be washed from the skin and clothing using soap and water. Please follow the recommended safety and handling guidelines outlined in our Safety & Handling Guidelines manual, which is available on request. For complete health and safety information, please see [SDS sheets on our website](#).

#### Material Handling

Cryogel® Z insulation when shipped in full rolls is typically 1.45 m (57 in) wide weighing up to 136kg (300 lb) per roll. Rolls can be moved manually with the use of a metal pipe or wooden 2x4 placed through the center of the roll and picked up from either end, or by using a pallet jack or forklift. Rolls can also be purchased in crates. Rolls should always be placed or stacked on their sides and should never be positioned upright on their ends as this may damage the exposed ends of the roll.



#### Preparation and Storage

Cryogel® Z insulation materials should be stored in a clean, dry and protected environment. If the material is stored in an outdoor setting, it should be placed on pallets and thoroughly covered with a waterproof tarp or plastic sheeting. Although the aerogel material is hydrophobic, all necessary measures should be taken to protect it from the weather.

To prepare for installation:

- Ensure that pressure testing of piping and fittings has been completed prior to installing insulation.
- Ensure that all pipe and fitting surfaces over which insulation is to be installed are clean and dry.
- Ensure that insulation is clean, dry, and in good mechanical condition. Wet, dirty, or damaged insulation is not acceptable for installation.
- Determine pipe size, pipe length, and number of layers of Cryogel® Z blanket required for the application.



**NOTE: More information on above sections can be found in our Safety & Handling Guidelines manual, which is available on request.**

**Optimal Work Setup**

To achieve the most productive work environment for use with Cryogel® Z insulation, we suggest the following setup.

**BULK CUTTING AREA**

This area will be used for cutting Cryogel® Z materials from full rolls into lengths required for the application, as well as cutting any preformed parts required to ease the installation process. This area should be setup in a covered and protected area. This area should contain several tables to accommodate the roll width and cutting length required for each component being worked. The roll of Cryogel® Z insulation should be located at the front of the table where it can be placed on a roller rack with a tube placed through the roll. Please refer to the Recommended Cutting Tools chart below for suggested tools for this application. Parts should be placed on pallets and covered, bagged, or wrapped in plastic before bringing to work area.



**WORK AREA**

Ideally the material should be placed as close to the work area as possible. Remove the materials from the packaging and distribute to the work location. Please refer to the cutting tools chart below for suggested tools for field applications.

Material	Cutting Tool ( <b>FIELD</b> or <b>SHOP</b> )					
	Scissors	Box Cutter	Pizza Wheel/ Electric	Slitter	Heated Knife	Dremel Oscillating Tool With MM430 blade
Cryogel® Z	<b>FIELD</b>	<b>FIELD</b>	<b>FIELD</b>	<b>SHOP</b>	<b>SHOP</b>	<b>SHOP</b>

**Cold Installation Overview**

This installation guide provides design and installation guidelines for the use of Cryogel® Z as thermal insulation and/or passive fire protection. It applies to piping and equipment operating at below-ambient service temperatures.

This guide references several accessory products for the complete installation of a Cryogenic insulation system. Descriptions, product names, manufacturers, and usage limitations for these recommended materials and accessories can be found in [Appendix A](#).

Expansion and contraction joints are not necessary with the Cryogel® Z insulation system.

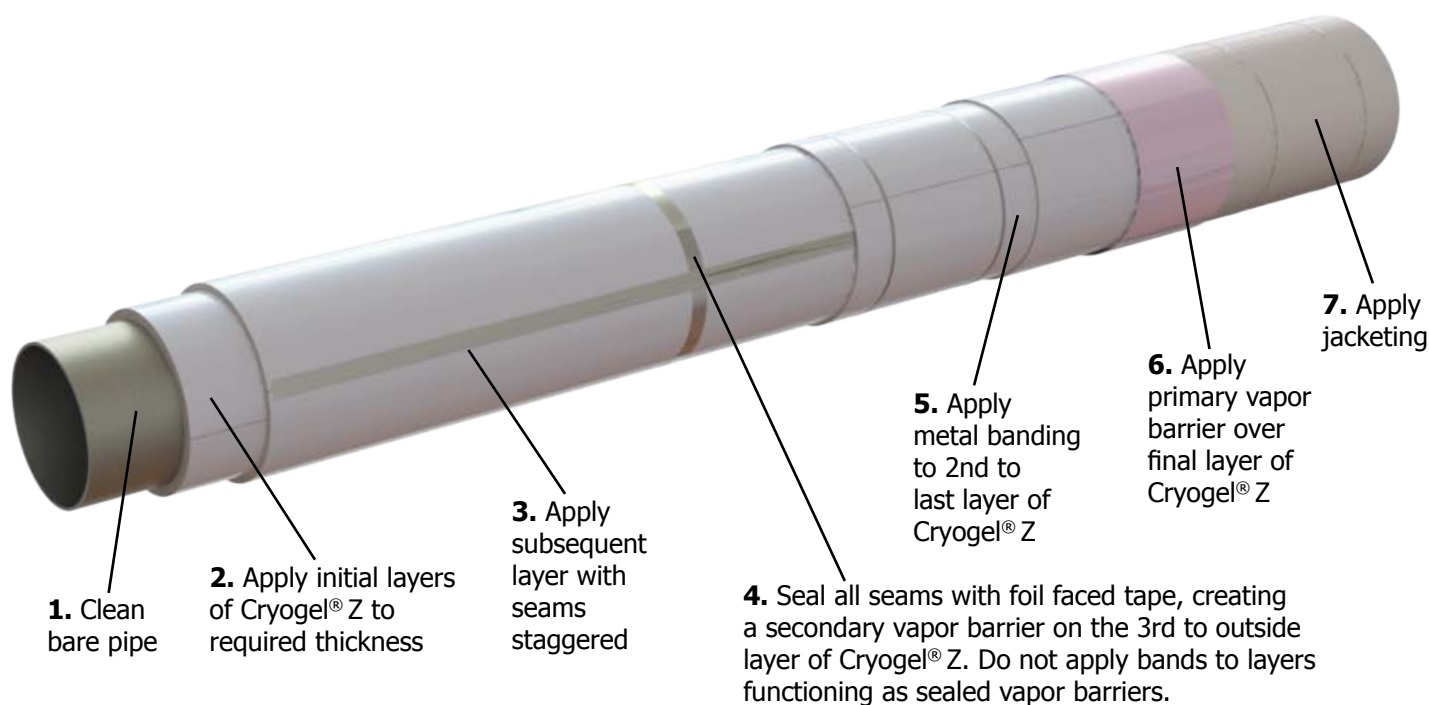

Figure 1.

#### Cold Installation Overview cont'd.

#### VAPOR BARRIERS

- Apply a primary vapor barrier consisting of a sheet mastic membrane or mastic over the final outermost layer of Cryogel® Z.
- For piping or equipment operating below -40°C (-40°F), install a secondary vapor barrier two layers beneath the primary vapor barrier by sealing all seams of the Cryogel® Z with foil faced tape (see Figures 1 and 2).
- Do not apply stainless steel bands directly to either the primary or secondary vapor barriers.
- Follow the schedule below for proper installation of vapor barriers and banding.

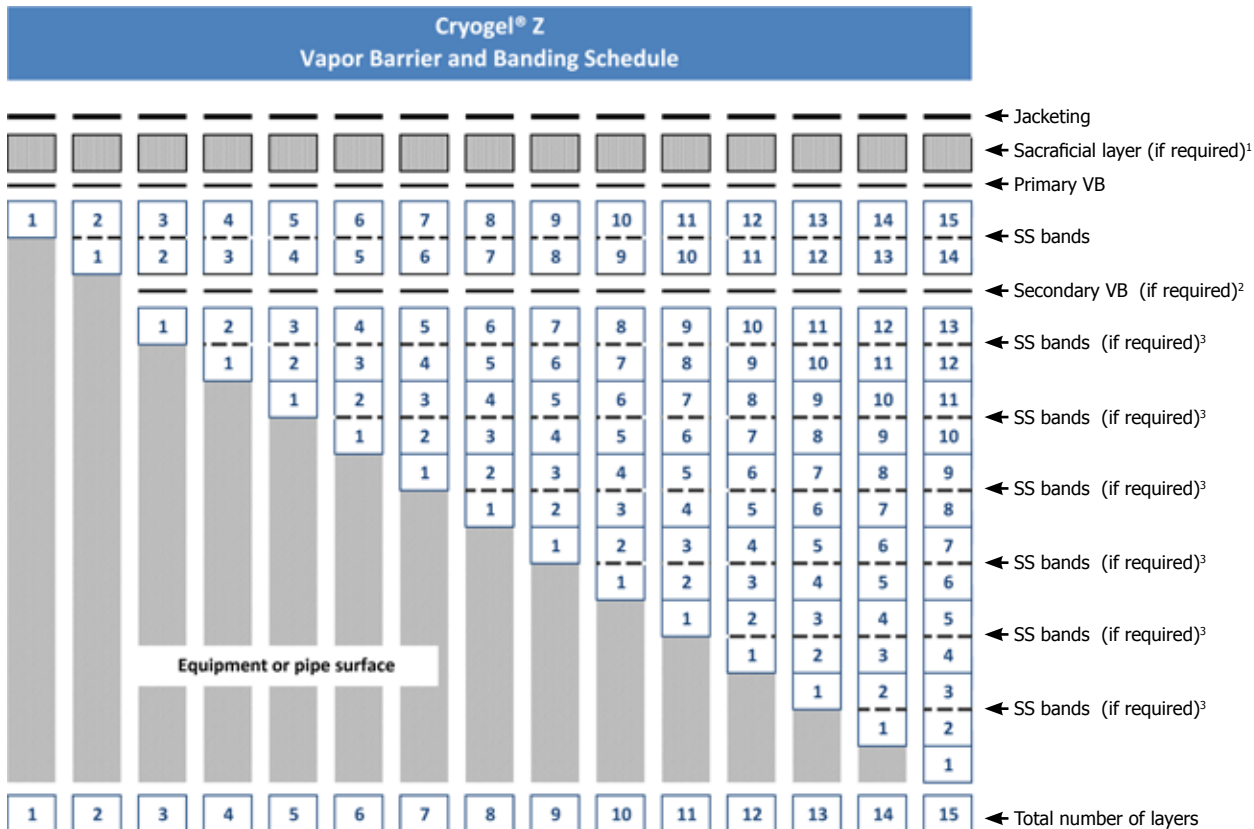

Figure 2: Vapor barrier and band locations for Cryogel Z installations of 1 to 15 layers.

**Notes:**

1. The sacrificial layer is only necessary when screws or rivets in the jacketing could puncture the vapor barrier.
2. The secondary vapor barrier is required only for service below -40°C (-40°F).
3. Intermediate stainless steel bands are only required on vertical piping and vessels, and for insulation that is also to serve as passive fire protection.

### Cold Installation Overview cont'd.

#### VAPOR STOPS

- To ensure end-to-end integrity of the vapor barrier, install vapor stops at all insulation terminations and penetrations, and on either side of all flanges, valves, hangars, and supports. See [Appendix A](#) for acceptable vapor stop materials.
- Tie the vapor stop into both the secondary (where required) and primary vapor barriers with a minimum lap of 38 mm (1.5 in), as illustrated in Figure 3.
- Construct all liquid- or paste-applied mastics and sealants with a membrane reinforcement.
- When vapor-stopping over the cut ends of the Cryogel<sup>®</sup> Z, it may be necessary to smooth over the ragged surface with a "bridge" layer of tape or Cryogel<sup>®</sup> Z (see example in Figure 3).

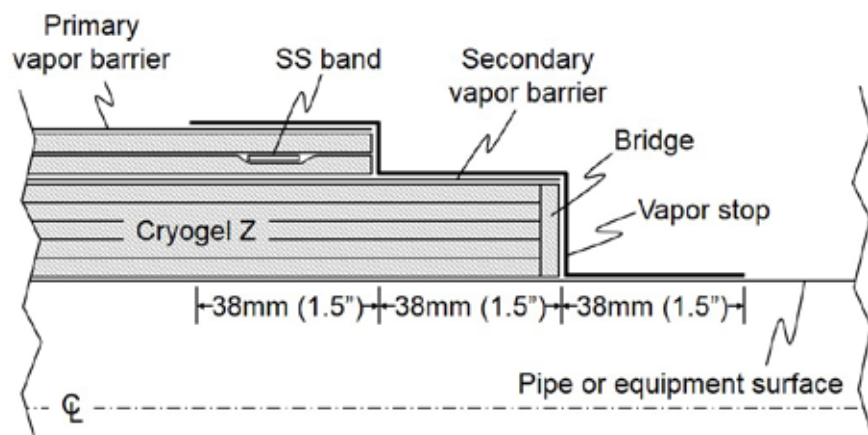

Figure 3: Typical vapor stop detail on a 7-layer termination, showing the tie-ins with both the primary and secondary vapor barriers.



#### INSTALLING CRYOGEL<sup>®</sup> Z FOR PASSIVE FIRE PROTECTION

- When designing for both thermal insulation and passive fire protection, use the greater of the two thickness requirements.
- Use stainless- or galvanized steel jacketing for situations where the thermal insulation is also to be used as passive fire protection.
- Where the insulation is to serve as passive fire protection, install additional intermediate banding over every second layer as shown in Figure 2. Space the bands 450 mm (18 in) apart.



**Cold Installation Overview cont'd.**
**SECURING THE CRYOGEL® Z**

- Place 19 mm (¾ in) stainless steel bands around the second-to-last layer of Cryogel® Z, between the primary and secondary vapor barrier layers. Space bands 450 mm (18 in) apart.
- On vertical piping and equipment, install additional intermediate banding over every fourth layer. Space bands 450 mm (18 in) apart.
- Do not apply stainless steel bands directly to either the primary or secondary vapor barriers.
- Follow banding instructions in Passive Fire Protection section above if installing Cryogel® Z for passive fire protection.

**JACKETING AND FINISHING**

- Cryogel® Z is compatible with all forms of jacketing, including metal cladding, PVC, mastic glass-mastic, glass reinforced plastic (GRP), and polymeric and asphaltic membrane systems. Refer to site specifications for jacketing installation procedures.
- Screws and rivets should be avoided unless absolutely necessary.
- In areas where screws or rivets are necessary to secure the jacketing (i.e., vessel heads), apply a sacrificial layer of 25 mm (1 in) polyolefin foam or alternative material (see [Appendix A](#)) to prevent puncture of the primary vapor barrier. Discrete strips – oriented to allow drainage – are preferred over full-area coverage.

#### Single Layer Installation

**1.** Cut the Cryogel® Z blanket to the length required for a complete wrap. The cut length may be determined by either wrapping a scrap piece around the pipe and marking the place where it overlaps, or consulting the cutting charts on [pages 23-32](#). Either a butt joint or lap joint is acceptable for the longitudinal seam.



**2.** Place the Cryogel® Z on the pipe and wrap it around the circumference of the pipe. The starting edge of the Cryogel® Z can be held in place by hand or with a strip of halogen-free spray adhesive.



**3.** Once wrapped around the pipe, the Cryogel® Z may be held in place using fiber-reinforced tape, wire, halogen-free spray adhesive, or banding.

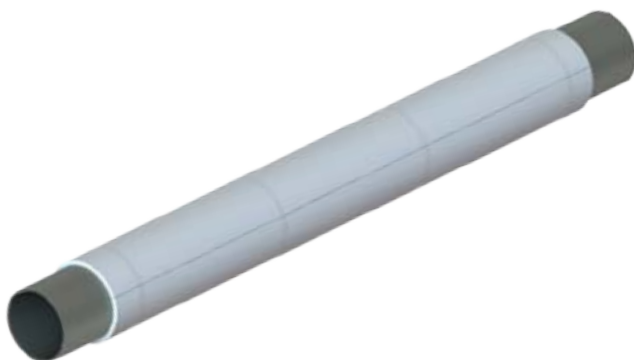

**4.** Single layer of Cryogel® Z showing a lap joint. When using a lap joint, it is good practice to orient the overlap with a downward-facing watershed.



#### Single Piece Multi-Wrap Installation

**1.** Multiple layers can be installed by using one continuous piece of Cryogel® Z insulation and overlapping it. First, cut the Cryogel® Z blanket to the length required. The length may be determined by consulting the cutting charts on [pages 23-32](#) and adding the lengths from the individual layers together. For ease of handling, it is recommended that the maximum length of Cryogel® Z be no longer than 3.3 m (10 ft).



**2.** Align the leading edge of the Cryogel® Z with the long axis of the pipe and wrap around the pipe. The starting edge of the Cryogel® Z can be held in place by hand or with a strip of halogen-free spray adhesive.

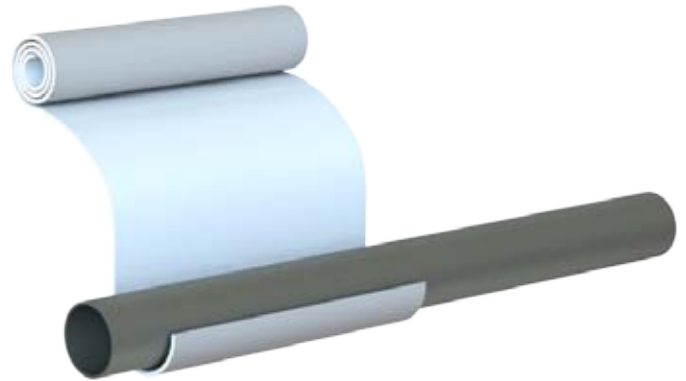

**3.** Overlap and continue around the circumference to achieve the multi-layer application.

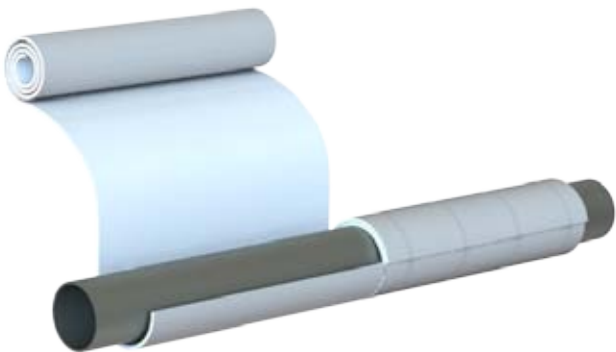

**4.** Once wrapped around the pipe, the Cryogel® Z may be held in place using fiber-reinforced tape, wire, halogen-free spray adhesive, or banding.



**5.** Follow the instructions on pages 6-8 for the proper installation of vapor barriers and vapor stops.

**6.** Finish with jacketing per site specifications.

**Multi-Layer Installation**

**1.** For applications that require the use of multiple layers of Cryogel® Z insulation, all circumferential and longitudinal joints shall staggered by a minimum of 100 mm (4 in).

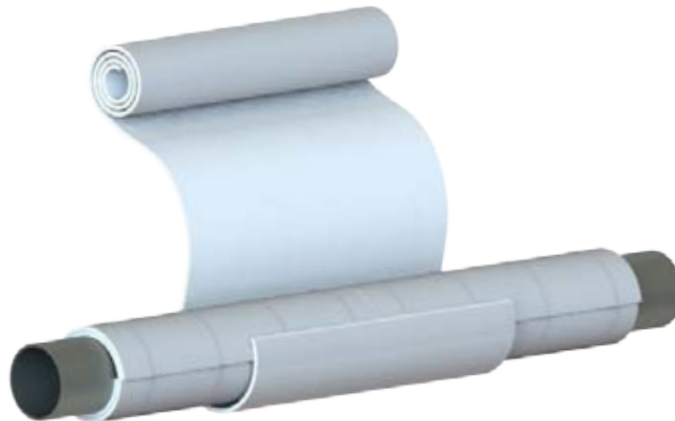

**2.** Once wrapped around the pipe, the Cryogel® Z insulation may be held in place using fiber-reinforced tape, wire, halogen-free spray adhesive, or banding.

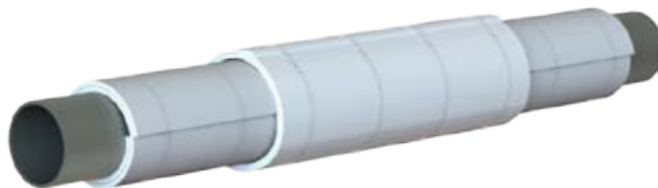

**3.** Follow the instructions on pages 6-8 for the proper installation of vapor barriers and vapor stops.

**4.** Finish with jacketing per site specifications.

**Small Bore Pipe - 15 to 100 mm (½ to 4 in) NPS**

For piping smaller than 100 mm (4 in) NPS, we suggest the use of V-grooved, cut-to-length materials. Another option is to use 5 mm (0.2 in) materials, as they are more flexible than their 10 mm (0.4 in) counterparts. Contact Aspen Aerogels at 508-691-1111 or [info.aerogel.com/contact](mailto:info.aerogel.com/contact) for details on local suppliers of pre-fabricated V-grooved material accessories.

**V-GROOVE**

- 1.** V-grooved pipe cover comes pre-cut to the particular pipe size and insulation thickness so that each layer comes to a perfect, butted closure.
- 2.** For multi-layer applications, align the grooves for better laydown, but stagger the longitudinal seams.



#### Pipe Fittings

##### PIPE ENDS

Install the Cryogel® Z blanket past the pipe end to the same distance as required for the thickness of the insulation.

Cut plugs from the Cryogel® Z to the diameter of the opening and install to match the thickness.

Install vapor barriers as required.

##### REDUCERS

Install the Cryogel® Z blanket to the same thickness as would be required for the piping using the same layout pattern as would be required for the metal cladding less the required overlaps.

Install each layer in a staggered fashion, then install vapor barriers as required.

##### TEES

Install the Cryogel® Z blanket using the same techniques as would be used for installing the cladding. Staircase the insulation joint. Contact Aspen Aerogels at 508-691-1111 or [info.aerogel.com/contact](mailto:info.aerogel.com/contact) for details on local suppliers of pre-cut tees.

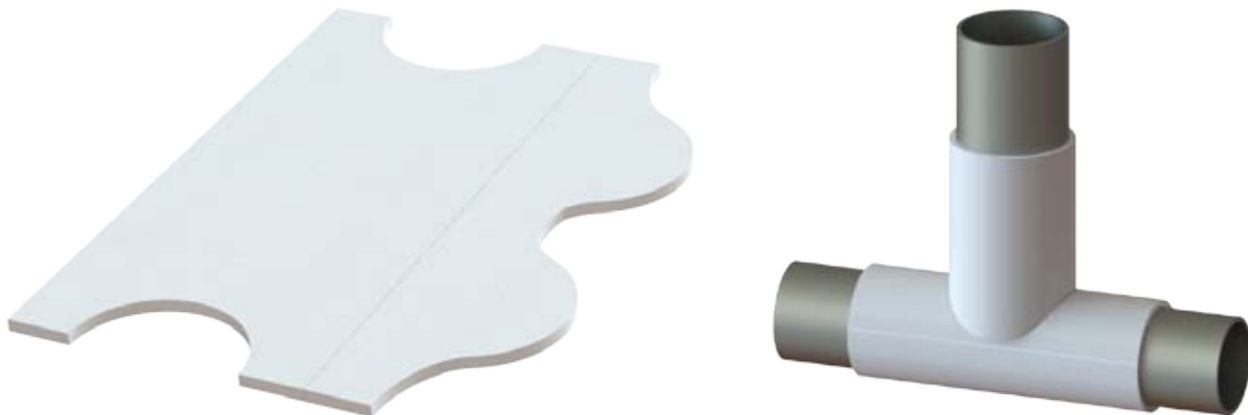

**45- and 90-Degree Elbows**

**Suggested Elbow Chart**

Pipe Size (NPS)		Elbow Type		
mm	inches	Pre-Cut	Gored	Stove Pipe
15 – 40	1/2 – 1 1/2	√		√
50 – 150	2 – 6	√	√	
200 – 300	8 – 12	√	√	
350 – 600	14 – 24	√	√	
650 – 900	26 – 36	√	√	
950 – 1,200	38 – 48	√	√	

The instructions on the following pages cover three types of elbows available for use with Cryogel® Z materials and installation suggestions.

Contact Aspen Aerogels at 508-691-1111 or [info.aerogel.com/contact](http://info.aerogel.com/contact) for details on local suppliers of pre-fabricated elbows and accessories.

**45- and 90-Degree Elbows**

**SINGLE-PIECE ELBOW FITTINGS**

Pre-fabricated elbows for piping NPS 200 mm (8 in) and smaller are based on a reverse gore-style pattern that gathers in the throat and is closed along the heel. Larger elbows are constructed of individual gores that get applied one at a time in the field.



1. Place the middle of the fitting along the inside (throat) of the pipe fitting.

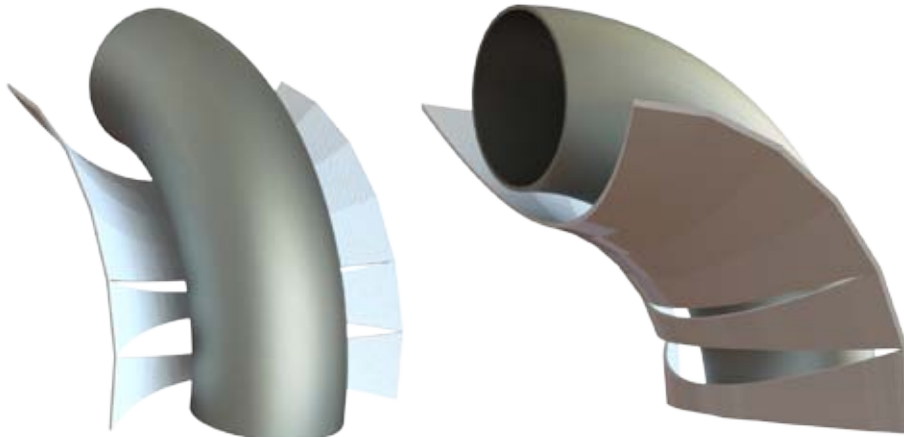



**45- and 90-Degree Elbows**

2. Tightly wrap material around to the heel, aligning the seam with the centerline of the fitting.



3. It is important that the Cryogel® Z material is tight to the elbow. Work excess material around the fitting towards the back side of the fitting until the butt joint is closed tightly. Apply fiber-reinforced tape, wire, or outward-clenching staples to secure each gore.



#### 45- and 90-Degree Elbows

**4.** Once all gores are secured, push material from both ends of the fitting cover to ensure all seams are tightly closed.

**5.** Apply all subsequent layers in a similar fashion. Note that the seams in some layers are specifically engineered to not line up with the ones beneath it. Also note that in multi-layer fittings, the inner layers will often have an extended tangent to provide a ship-lap joint for the adjacent line insulation.

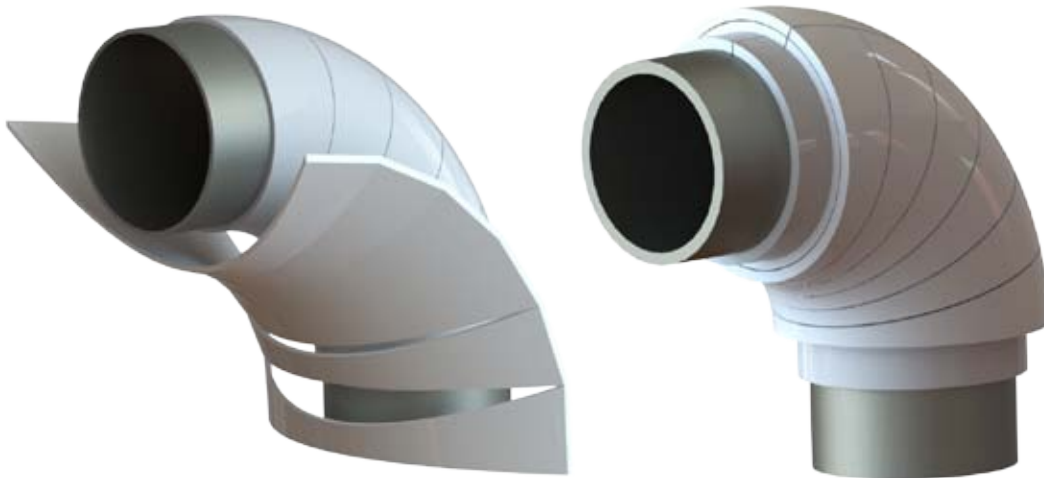

**6.** Follow the instructions on pages 6-8 for the proper installation of vapor barriers and vapor stops.

**7.** Finish with jacketing per site specifications.

**45- and 90-Degree Elbows**

**GORED ELBOW FITTINGS**

This style of elbow can be cut by the contractor using the same principles that are used to fabricate metal gored elbow, minus the overlaps.

Cut the Cryogel® Z blanket to the required length and cut as per the gore pattern. Install each layer, staggering the seams where possible. This can be achieved by slitting one of the gored sections down the center to create half a gore. This half section will be used for the starter and finisher of the staggered layer. The gored elbow may also be achieved by separating the pre-cut elbows and installing one gore at a time.

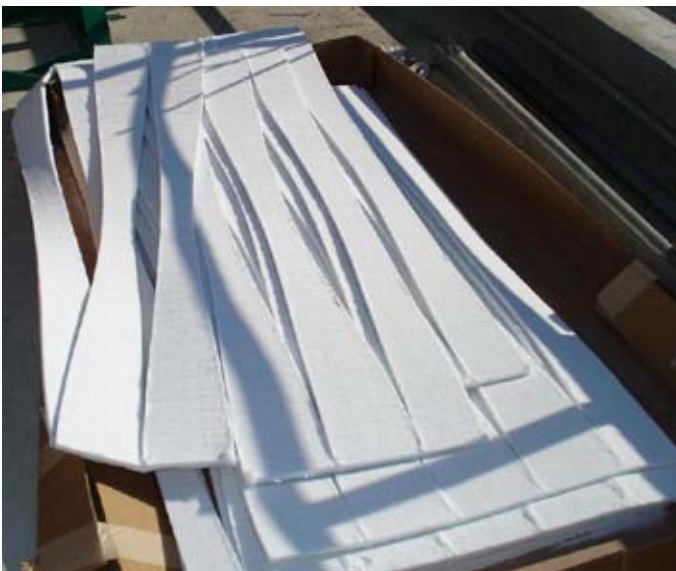

**STOVE PIPE**

We recommend that this style of elbow only be used on small bore piping where the fabrication of the above elbow styles can't be done due to limited elbow throat space. In order to fabricate this elbow, we recommend that the pre-formed pipe covering be cut at a 45-degree angle with the sections adjoined in the elbow to form the 90-degree elbow.

**Valves and Flanges**

This section gives the general techniques for insulating flanged valves. Because of the variety in valves shapes and designs, some modifications to these instructions may be necessary.

**1.** Install vapor stops on adjacent line insulation on either side of the valve.



**2.** Convert the complex valve shape into a series of simple cylinders by filling all void spaces with mineral wool, glass fiber or Cryogel Z. This should include filling the area between the vapor stops and the flange face to a depth that is 20 mm (0.8 in) thinner than the adjacent line insulation.



**3.** Install two layers of Cryogel Z over the void-fill material, building it up to the same thickness as the adjacent Cryogel Z line insulation.



**4.** Build up the shoulders on either side of the flanges with Cryogel Z to achieve the same diameter as the flange face, making sure the width of the shoulder covers the vapor stop completely.



**Valves and Flanges**

**5.** Measure the distance between the two outer faces of the Cryogel Z shoulders to determine the width of the valve body insulation.

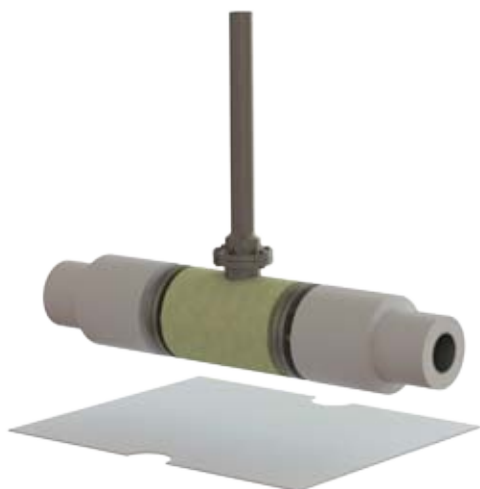

**6.** Install the valve body insulation making sure to stagger the cutout on each wrap of Cryogel Z. Build up the valve body insulation to the same thickness as the adjacent line insulation. Attachment of Cryogel Z may be done with tape, wire, halogen-free spray adhesive, or banding.



**7.** Insulate the bonnet area with Cryogel Z. Alternate body- and bonnet-insulation every second layer to eliminate through-seams. Apply foil-faced tape to 3rd to last layer, thereby creating the secondary vapor barrier.



**8.** Secure the 2nd to last layer with banding.



**Valves and Flanges**

**9.** Apply the final layer of Cryogel Z. Apply a primary vapor barrier over the final layer of Cryogel Z. Install a vapor stop down to valve stem.



**10.** Finish with jacketing per site specifications. Once installation of the Cryogel Z insulation layers is complete, the finished valve should resemble below.



**Filling Cracks and Voids**

Filling small cracks and voids can be achieved by using mineral wool or glass fiber or by delaminating the Cryogel® Z to a workable thickness and pushing it into the crack with the use of a knife. For larger cracks and voids, it is recommended that strips or sections be cut from a blanket and added. When delaminating, take care not to shred the material causing it to loosen the Cryogel® Z material from the section. It is not recommended that it be shredded into fiber in order to do this, as this will cause the loss of aerogel from the material.

#### Cryogel® Z 5 mm Blanket Cut Chart (cm)

Material Stretchout for Each Layer (cm)												
NPS (mm)	Number of Layers											
	1	2	3	4	5	6	7	8	9	10	11	12
15	10.0	13.4	16.7	20.0	23.4	26.7	30.0	33.3	36.7	40.0	43.3	46.7
20	11.7	15.0	18.4	21.7	25.0	28.4	31.7	35.0	38.3	41.7	45.0	48.3
25	13.8	17.2	20.5	23.8	27.1	30.5	33.8	37.1	40.5	43.8	47.1	50.5
32	16.6	19.9	23.2	26.6	29.9	33.2	36.6	39.9	43.2	46.5	49.9	53.2
40	18.5	21.8	25.2	28.5	31.8	35.1	38.5	41.8	45.1	48.5	51.8	55.1
50	22.3	25.6	28.9	32.3	35.6	38.9	42.3	45.6	48.9	52.3	55.6	58.9
65	26.3	29.6	32.9	36.3	39.6	42.9	46.3	49.6	52.9	56.2	59.6	62.9
80	31.3	34.6	37.9	41.2	44.6	47.9	51.2	54.6	57.9	61.2	64.6	67.9
90	35.2	38.6	41.9	45.2	48.6	51.9	55.2	58.6	61.9	65.2	68.5	71.9
100	39.2	42.6	45.9	49.2	52.6	55.9	59.2	62.5	65.9	69.2	72.5	75.9
115	43.2	46.6	49.9	53.2	56.5	59.9	63.2	66.5	69.9	73.2	76.5	79.9
125	47.7	51.1	54.4	57.7	61.0	64.4	67.7	71.0	74.4	77.7	81.0	84.4
150	56.2	59.5	62.9	66.2	69.5	72.8	76.2	79.5	82.8	86.2	89.5	92.8
200	72.2	75.5	78.8	82.1	85.5	88.8	92.1	95.5	98.8	102.1	105.5	108.8
250	89.1	92.4	95.8	99.1	102.4	105.8	109.1	112.4	115.8	119.1	122.4	125.7
300	105.1	108.4	111.7	115.1	118.4	121.7	125.1	128.4	131.7	135.0	138.4	141.7
350	115.0	118.4	121.7	125.0	128.4	131.7	135.0	138.4	141.7	145.0	148.3	151.7
400	131.0	134.3	137.7	141.0	144.3	147.7	151.0	154.3	157.6	161.0	164.3	167.6
450	147.0	150.3	153.6	157.0	160.3	163.6	166.9	170.3	173.6	176.9	180.3	183.6
500	162.9	166.3	169.6	172.9	176.2	179.6	182.9	186.2	189.6	192.9	196.2	199.6
550	178.9	182.2	185.5	188.9	192.2	195.5	198.9	202.2	205.5	208.9	212.2	215.5
600	194.8	198.2	201.5	204.8	208.2	211.5	214.8	218.2	221.5	224.8	228.1	231.5
650	210.8	214.1	217.5	220.8	224.1	227.5	230.8	234.1	237.4	240.8	244.1	247.4
700	226.8	230.1	233.4	236.8	240.1	243.4	246.7	250.1	253.4	256.7	260.1	263.4
750	242.7	246.0	249.4	252.7	256.0	259.4	262.7	266.0	269.4	272.7	276.0	279.4
800	258.7	262.0	265.3	268.7	272.0	275.3	278.7	282.0	285.3	288.6	292.0	295.3
850	274.6	278.0	281.3	284.6	288.0	291.3	294.6	297.9	301.3	304.6	307.9	311.3
900	290.6	293.9	297.3	300.6	303.9	307.2	310.6	313.9	317.2	320.6	323.9	327.2
950	306.6	309.9	313.2	316.5	319.9	323.2	326.5	329.9	333.2	336.5	339.9	343.2
1000	322.5	325.8	329.2	332.5	335.8	339.2	342.5	345.8	349.2	352.5	355.8	359.1
1050	338.5	341.8	345.1	348.5	351.8	355.1	358.5	361.8	365.1	368.4	371.8	375.1
1100	354.4	357.8	361.1	364.4	367.8	371.1	374.4	377.7	381.1	384.4	387.7	391.1
1150	370.4	373.7	377.1	380.4	383.7	387.0	390.4	393.7	397.0	400.4	403.7	407.0
1200	386.4	389.7	393.0	396.3	399.7	403.0	406.3	409.7	413.0	416.3	419.7	423.0

NOTES:

All lengths assume a butt joint with no overlap.

All measurements should be verified with a test piece.

Contact Aspen Aerogels for additional sizes.

#### Cryogel® Z 5 mm (0.2 in) Blanket Cut Chart (inches)

Material Stretchout for Each Layer (inches)												
NPS (in.)	Number of Layers											
	1	2	3	4	5	6	7	8	9	10	11	12
0.5	3.9	5.3	6.6	7.9	9.2	10.5	11.8	13.1	14.4	15.7	17.1	18.4
0.75	4.6	5.9	7.2	8.5	9.9	11.2	12.5	13.8	15.1	16.4	17.7	19.0
1	5.4	6.8	8.1	9.4	10.7	12.0	13.3	14.6	15.9	17.2	18.6	19.9
1.25	6.5	7.8	9.1	10.5	11.8	13.1	14.4	15.7	17.0	18.3	19.6	20.9
1.5	7.3	8.6	9.9	11.2	12.5	13.8	15.1	16.5	17.8	19.1	20.4	21.7
2	8.8	10.1	11.4	12.7	14.0	15.3	16.6	17.9	19.3	20.6	21.9	23.2
2.5	10.3	11.7	13.0	14.3	15.6	16.9	18.2	19.5	20.8	22.1	23.5	24.8
3	12.3	13.6	14.9	16.2	17.6	18.9	20.2	21.5	22.8	24.1	25.4	26.7
3.5	13.9	15.2	16.5	17.8	19.1	20.4	21.7	23.1	24.4	25.7	27.0	28.3
4	15.4	16.8	18.1	19.4	20.7	22.0	23.3	24.6	25.9	27.2	28.6	29.9
4.5	17.0	18.3	19.6	21.0	22.3	23.6	24.9	26.2	27.5	28.8	30.1	31.4
5	18.8	20.1	21.4	22.7	24.0	25.3	26.7	28.0	29.3	30.6	31.9	33.2
6	22.1	23.4	24.7	26.1	27.4	28.7	30.0	31.3	32.6	33.9	35.2	36.5
8	28.4	29.7	31.0	32.3	33.7	35.0	36.3	37.6	38.9	40.2	41.5	42.8
10	35.1	36.4	37.7	39.0	40.3	41.6	42.9	44.3	45.6	46.9	48.2	49.5
12	41.4	42.7	44.0	45.3	46.6	47.9	49.2	50.5	51.9	53.2	54.5	55.8
14	45.3	46.6	47.9	49.2	50.5	51.8	53.2	54.5	55.8	57.1	58.4	59.7
16	51.6	52.9	54.2	55.5	56.8	58.1	59.4	60.8	62.1	63.4	64.7	66.0
18	57.9	59.2	60.5	61.8	63.1	64.4	65.7	67.0	68.3	69.7	71.0	72.3
20	64.1	65.5	66.8	68.1	69.4	70.7	72.0	73.3	74.6	75.9	77.3	78.6
22	70.4	71.7	73.0	74.4	75.7	77.0	78.3	79.6	80.9	82.2	83.5	84.8
24	76.7	78.0	79.3	80.6	82.0	83.3	84.6	85.9	87.2	88.5	89.8	91.1
26	83.0	84.3	85.6	86.9	88.2	89.5	90.9	92.2	93.5	94.8	96.1	97.4
28	89.3	90.6	91.9	93.2	94.5	95.8	97.1	98.5	99.8	101.1	102.4	103.7
30	95.6	96.9	98.2	99.5	100.8	102.1	103.4	104.7	106.0	107.4	108.7	110.0
32	101.8	103.2	104.5	105.8	107.1	108.4	109.7	111.0	112.3	113.6	115.0	116.3
34	108.1	109.4	110.7	112.1	113.4	114.7	116.0	117.3	118.6	119.9	121.2	122.5
36	114.4	115.7	117.0	118.3	119.7	121.0	122.3	123.6	124.9	126.2	127.5	128.8
38	120.7	122.0	123.3	124.6	125.9	127.2	128.6	129.9	131.2	132.5	133.8	135.1
40	127.0	128.3	129.6	130.9	132.2	133.5	134.8	136.2	137.5	138.8	140.1	141.4
42	133.3	134.6	135.9	137.2	138.5	139.8	141.1	142.4	143.7	145.1	146.4	147.7
44	139.5	140.9	142.2	143.5	144.8	146.1	147.4	148.7	150.0	151.3	152.7	154.0
46	145.8	147.1	148.4	149.8	151.1	152.4	153.7	155.0	156.3	157.6	158.9	160.2
48	152.1	153.4	154.7	156.0	157.4	158.7	160.0	161.3	162.6	163.9	165.2	166.5

**NOTES:**

All lengths assume a butt joint with no overlap.

All measurements should be verified with a test piece.

Contact Aspen Aerogels for additional sizes.



#### Cryogel® Z 10 mm Blanket Cut Chart (cm)

Material Stretchout for Each Layer (cm)												
NPS (mm)	Number of Layers											
	1	2	3	4	5	6	7	8	9	10	11	12
15	13.3	19.9	26.5	33.1	39.7	46.3	52.9	59.5	66.1	72.7	79.3	85.9
20	15.0	21.6	28.2	34.8	41.4	48.0	54.6	61.2	67.8	74.4	80.9	87.5
25	17.1	23.7	30.3	36.9	43.5	50.1	56.7	63.3	69.9	76.5	83.1	89.7
32	19.8	26.4	33.0	39.6	46.2	52.8	59.4	66.0	72.6	79.2	85.8	92.4
40	21.8	28.4	35.0	41.6	48.1	54.7	61.3	67.9	74.5	81.1	87.7	94.3
50	25.5	32.1	38.7	45.3	51.9	58.5	65.1	71.7	78.3	84.9	91.5	98.1
65	29.5	36.1	42.7	49.3	55.9	62.5	69.1	75.7	82.3	88.9	95.5	102.1
80	34.5	41.1	47.7	54.3	60.9	67.5	74.1	80.7	87.3	93.9	100.5	107.1
90	38.5	45.1	51.7	58.3	64.9	71.5	78.1	84.7	91.3	97.9	104.5	111.1
100	42.5	49.1	55.7	62.3	68.9	75.5	82.1	88.7	95.3	101.9	108.5	115.1
115	46.5	53.1	59.7	66.3	72.9	79.5	86.1	92.7	99.3	105.9	112.5	119.1
125	51.0	57.6	64.2	70.8	77.4	84.0	90.6	97.2	103.8	110.4	117.0	123.6
150	59.5	66.1	72.7	79.3	85.9	92.4	99.0	105.6	112.2	118.8	125.4	132.0
200	75.4	82.0	88.6	95.2	101.8	108.4	115.0	121.6	128.2	134.8	141.4	148.0
250	92.4	99.0	105.6	112.2	118.8	125.4	132.0	138.6	145.2	151.8	158.4	164.9
300	108.3	114.9	121.5	128.1	134.7	141.3	147.9	154.5	161.1	167.7	174.3	180.9
350	118.3	124.9	131.5	138.1	144.7	151.3	157.9	164.5	171.1	177.7	184.3	190.9
400	134.3	140.9	147.5	154.1	160.7	167.3	173.9	180.5	187.1	193.6	200.2	206.8
450	150.2	156.8	163.4	170.0	176.6	183.2	189.8	196.4	203.0	209.6	216.2	222.8
500	166.2	172.8	179.4	186.0	192.6	199.2	205.8	212.4	219.0	225.6	232.2	238.8
550	182.1	188.7	195.3	201.9	208.5	215.1	221.7	228.3	234.9	241.5	248.1	254.7
600	198.1	204.7	211.3	217.9	224.5	231.1	237.7	244.3	250.9	257.5	264.1	270.7
650	214.1	220.7	227.3	233.9	240.5	247.1	253.7	260.2	266.8	273.4	280.0	286.6
700	230.0	236.6	243.2	249.8	256.4	263.0	269.6	276.2	282.8	289.4	296.0	302.6
750	246.0	252.6	259.2	265.8	272.4	279.0	285.6	292.2	298.8	305.4	312.0	318.6
800	261.9	268.5	275.1	281.7	288.3	294.9	301.5	308.1	314.7	321.3	327.9	334.5
850	277.9	284.5	291.1	297.7	304.3	310.9	317.5	324.1	330.7	337.3	343.9	350.5
900	293.9	300.5	307.1	313.7	320.3	326.9	333.4	340.0	346.6	353.2	359.8	366.4
950	309.8	316.4	323.0	329.6	336.2	342.8	349.4	356.0	362.6	369.2	375.8	382.4
1000	325.8	332.4	339.0	345.6	352.2	358.8	365.4	372.0	378.6	385.2	391.8	398.4
1050	341.7	348.3	354.9	361.5	368.1	374.7	381.3	387.9	394.5	401.1	407.7	414.3
1100	357.7	364.3	370.9	377.5	384.1	390.7	397.3	403.9	410.5	417.1	423.7	430.3
1150	373.7	380.3	386.9	393.5	400.1	406.6	413.2	419.8	426.4	433.0	439.6	446.2
1200	389.6	396.2	402.8	409.4	416.0	422.6	429.2	435.8	442.4	449.0	455.6	462.2

NOTES:

All lengths assume a butt joint with no overlap.

All measurements should be verified with a test piece.

Note that for best fit on pipes smaller than 100 mm (4 in) NPS, use 5 mm blanket or 10 mm V-groove.

Contact Aspen Aerogels for additional sizes.

#### Cryogel® Z 10 mm (0.4 in) Blanket Cut Chart (inches)

Material Stretchout for Each Layer (inches)												
NPS (in.)	Number of Layers											
	1	2	3	4	5	6	7	8	9	10	11	12
0.5	5.2	7.8	10.4	13.0	15.6	18.2	20.8	23.4	26.0	28.6	31.2	33.8
0.75	5.9	8.5	11.1	13.7	16.3	18.9	21.5	24.1	26.7	29.3	31.9	34.5
1	6.7	9.3	11.9	14.5	17.1	19.7	22.3	24.9	27.5	30.1	32.7	35.3
1.25	7.8	10.4	13.0	15.6	18.2	20.8	23.4	26.0	28.6	31.2	33.8	36.4
1.5	8.6	11.2	13.8	16.4	19.0	21.6	24.2	26.7	29.3	31.9	34.5	37.1
2	10.1	12.7	15.3	17.9	20.4	23.0	25.6	28.2	30.8	33.4	36.0	38.6
2.5	11.6	14.2	16.8	19.4	22.0	24.6	27.2	29.8	32.4	35.0	37.6	40.2
3	13.6	16.2	18.8	21.4	24.0	26.6	29.2	31.8	34.4	37.0	39.6	42.2
3.5	15.2	17.8	20.4	23.0	25.6	28.2	30.7	33.3	35.9	38.5	41.1	43.7
4	16.7	19.3	21.9	24.5	27.1	29.7	32.3	34.9	37.5	40.1	42.7	45.3
4.5	18.3	20.9	23.5	26.1	28.7	31.3	33.9	36.5	39.1	41.7	44.3	46.9
5	20.1	22.7	25.3	27.9	30.5	33.1	35.7	38.3	40.9	43.5	46.0	48.6
6	23.4	26.0	28.6	31.2	33.8	36.4	39.0	41.6	44.2	46.8	49.4	52.0
8	29.7	32.3	34.9	37.5	40.1	42.7	45.3	47.9	50.5	53.1	55.7	58.3
10	36.4	39.0	41.6	44.2	46.8	49.4	52.0	54.6	57.1	59.7	62.3	64.9
12	42.7	45.3	47.8	50.4	53.0	55.6	58.2	60.8	63.4	66.0	68.6	71.2
14	46.6	49.2	51.8	54.4	57.0	59.6	62.2	64.8	67.4	70.0	72.6	75.2
16	52.9	55.5	58.1	60.7	63.3	65.8	68.4	71.0	73.6	76.2	78.8	81.4
18	59.1	61.7	64.3	66.9	69.5	72.1	74.7	77.3	79.9	82.5	85.1	87.7
20	65.4	68.0	70.6	73.2	75.8	78.4	81.0	83.6	86.2	88.8	91.4	94.0
22	71.7	74.3	76.9	79.5	82.1	84.7	87.3	89.9	92.5	95.1	97.7	100.3
24	78.0	80.6	83.2	85.8	88.4	91.0	93.6	96.2	98.8	101.4	104.0	106.6
26	84.3	86.9	89.5	92.1	94.7	97.3	99.9	102.5	105.1	107.7	110.3	112.8
28	90.6	93.2	95.8	98.4	101.0	103.5	106.1	108.7	111.3	113.9	116.5	119.1
30	96.8	99.4	102.0	104.6	107.2	109.8	112.4	115.0	117.6	120.2	122.8	125.4
32	103.1	105.7	108.3	110.9	113.5	116.1	118.7	121.3	123.9	126.5	129.1	131.7
34	109.4	112.0	114.6	117.2	119.8	122.4	125.0	127.6	130.2	132.8	135.4	138.0
36	115.7	118.3	120.9	123.5	126.1	128.7	131.3	133.9	136.5	139.1	141.7	144.3
38	122.0	124.6	127.2	129.8	132.4	135.0	137.6	140.2	142.8	145.4	148.0	150.5
40	128.3	130.9	133.5	136.1	138.7	141.2	143.8	146.4	149.0	151.6	154.2	156.8
42	134.5	137.1	139.7	142.3	144.9	147.5	150.1	152.7	155.3	157.9	160.5	163.1
44	140.8	143.4	146.0	148.6	151.2	153.8	156.4	159.0	161.6	164.2	166.8	169.4
46	147.1	149.7	152.3	154.9	157.5	160.1	162.7	165.3	167.9	170.5	173.1	175.7
48	153.4	156.0	158.6	161.2	163.8	166.4	169.0	171.6	174.2	176.8	179.4	182.0

**NOTES:**

All lengths assume a butt joint with no overlap.

All measurements at left should be verified with a test piece.

Note that for best fit on pipes smaller than 4" NPS, use 0.2 in (5 mm) blanket or 0.4 in (10 mm) V-groove.

Contact Aspen Aerogels for additional sizes.

#### Cryogel® Z Insulation Cladding Cut Chart (cm)

Cryogel Z Thickness (mm)																
NPS (mm)	5 mm	10 mm	15 mm	20 mm	25 mm	30 mm	35 mm	40 mm	50 mm	60 mm	70 mm	80 mm	90 mm	100 mm	110 mm	120mm
	Cladding Cut Length (cm)															
15	15.1	18.4	21.8	25.0	28.4	31.6	35.1	38.2	44.8	51.4	58.0	64.6	71.2	77.8	84.4	91.0
20	16.8	20.1	23.4	26.7	30.1	33.3	36.8	39.8	46.4	53.0	59.6	66.2	72.8	79.4	86.0	92.6
25	18.9	22.2	25.6	28.8	32.2	35.4	38.9	42.0	48.6	55.2	61.8	68.4	74.9	81.5	88.1	94.7
32	21.7	24.9	28.3	31.5	35.0	38.1	41.6	44.7	51.3	57.9	64.5	71.1	77.7	84.3	90.9	97.5
40	23.6	26.8	30.2	33.4	36.9	40.0	43.6	46.6	53.2	59.8	66.4	73.0	79.6	86.2	92.8	99.4
50	27.4	30.6	34.0	37.2	40.7	43.8	47.3	50.4	57.0	63.6	70.2	76.8	83.4	90.0	96.6	103.2
65	31.4	34.6	38.0	41.2	44.7	47.8	51.3	54.4	61.0	67.6	74.2	80.8	87.4	94.0	100.6	107.2
80	36.3	39.6	43.0	46.2	49.7	52.8	56.3	59.4	66.0	72.6	79.2	85.8	92.4	99.0	105.6	112.2
90	40.3	43.6	47.0	50.2	53.6	56.8	60.3	63.4	70.0	76.6	83.2	89.8	96.4	103.0	109.6	116.2
100	44.3	47.6	51.0	54.2	57.6	60.8	64.3	67.4	74.0	80.6	87.2	93.8	100.4	107.0	113.6	120.2
115	48.3	51.6	55.0	58.2	61.6	64.8	68.3	71.4	78.0	84.6	91.2	97.8	104.4	111.0	117.5	124.1
125	52.8	56.1	59.5	62.7	66.1	69.3	72.8	75.9	82.5	89.1	95.7	102.2	108.8	115.4	122.0	128.6
150	61.3	64.5	67.9	71.1	74.6	77.7	81.3	84.3	90.9	97.5	104.1	110.7	117.3	123.9	130.5	137.1
200	77.2	80.5	83.9	87.1	90.6	93.7	97.2	100.3	106.9	113.5	120.1	126.7	133.3	139.9	146.5	153.1
250	94.2	97.5	100.9	104.1	107.5	110.7	114.2	117.3	123.8	130.4	137.0	143.6	150.2	156.8	163.4	170.0
300	110.2	113.4	116.8	120.0	123.5	126.6	130.1	133.2	139.8	146.4	153.0	159.6	166.2	172.8	179.4	186.0
350	120.1	123.4	126.8	130.0	133.4	136.6	140.1	143.2	149.8	156.4	163.0	169.6	176.2	182.8	189.4	196.0
400	136.1	139.4	142.7	145.9	149.4	152.5	156.1	159.1	165.7	172.3	178.9	185.5	192.1	198.7	205.3	211.9
450	152.0	155.3	158.7	161.9	165.4	168.5	172.0	175.1	181.7	188.3	194.9	201.5	208.1	214.7	221.3	227.9
500	168.0	171.3	174.7	177.9	181.3	184.5	188.0	191.1	197.7	204.3	210.9	217.5	224.0	230.6	237.2	243.8
550	184.0	187.2	190.6	193.8	197.3	200.4	203.9	207.0	213.6	220.2	226.8	233.4	240.0	246.6	253.2	259.8
600	199.9	203.2	206.6	209.8	213.2	216.4	219.9	223.0	229.6	236.2	242.8	249.4	256.0	262.6	269.2	275.8
650	215.9	219.1	222.5	225.7	229.2	232.3	235.9	238.9	245.5	252.1	258.7	265.3	271.9	278.5	285.1	291.7
700	231.8	235.1	238.5	241.7	245.2	248.3	251.8	254.9	261.5	268.1	274.7	281.3	287.9	294.5	301.1	307.7
750	247.8	251.1	254.5	257.7	261.1	264.3	267.8	270.9	277.5	284.1	290.7	297.2	303.8	310.4	317.0	323.6
800	263.8	267.0	270.4	273.6	277.1	280.2	283.7	286.8	293.4	300.0	306.6	313.2	319.8	326.4	333.0	339.6
850	279.7	283.0	286.4	289.6	293.0	296.2	299.7	302.8	309.4	316.0	322.6	329.2	335.8	342.4	349.0	355.6
900	295.7	298.9	302.3	305.5	309.0	312.1	315.7	318.7	325.3	331.9	338.5	345.1	351.7	358.3	364.9	371.5
950	311.6	314.9	318.3	321.5	325.0	328.1	331.6	334.7	341.3	347.9	354.5	361.1	367.7	374.3	380.9	387.5
1000	327.6	330.9	334.3	337.5	340.9	344.1	347.6	350.7	357.3	363.8	370.4	377.0	383.6	390.2	396.8	403.4
1050	343.6	346.8	350.2	353.4	356.9	360.0	363.5	366.6	373.2	379.8	386.4	393.0	399.6	406.2	412.8	419.4
1100	359.5	362.8	366.2	369.4	372.8	376.0	379.5	382.6	389.2	395.8	402.4	409.0	415.6	422.2	428.8	435.4
1150	375.5	378.7	382.1	385.3	388.8	391.9	395.5	398.5	405.1	411.7	418.3	424.9	431.5	438.1	444.7	451.3
1200	391.4	394.7	398.1	401.3	404.8	407.9	411.4	414.5	421.1	427.7	434.3	440.9	447.5	454.1	460.7	467.3

NOTES:

Areas shaded in grey indicate a finished diameter less than 75 mm. Depending on equipment, rolling metal to a finished diameter less than 75 mm may be problematic. Contact Aspen Aerogels for recommended solutions.

All cut lengths are based on a 50 mm overlap and do not include for safety edge. Additional amounts required for larger overlap or safety edge should be added.

All measurements at left should be verified with a test piece.

Contact Aspen Aerogels for additional sizes.

#### Cryogel® Z Insulation Cladding Cut Chart (inches)

Cryogel Z Thickness (inches (mm))																
NPS (in.)	0.2 in. (5mm)	0.4 in. (10mm)	0.6 in. (15mm)	0.8 in. (20mm)	1.0 in. (25mm)	1.2 in. (30mm)	1.4 in. (35mm)	1.6 in. (40mm)	2.0 in. (50mm)	2.4 in. (60mm)	2.8 in. (70mm)	3.2 in. (80mm)	3.6 in. (90mm)	4.0 in. (100mm)	4.4 in. (110mm)	4.8 in. (120mm)
	Cladding Cut Length (inches)															
0.5	5.9	7.2	8.6	9.8	11.2	12.4	13.8	15.0	17.6	20.2	22.8	25.4	28.0	30.6	33.2	35.8
0.75	6.6	7.9	9.2	10.5	11.9	13.1	14.5	15.7	18.3	20.9	23.5	26.1	28.7	31.3	33.9	36.5
1	7.4	8.7	10.1	11.3	12.7	13.9	15.3	16.5	19.1	21.7	24.3	26.9	29.5	32.1	34.7	37.3
1.25	8.5	9.8	11.1	12.4	13.8	15.0	16.4	17.6	20.2	22.8	25.4	28.0	30.6	33.2	35.8	38.4
1.5	9.3	10.6	11.9	13.2	14.5	15.8	17.1	18.4	21.0	23.6	26.2	28.7	31.3	33.9	36.5	39.1
2	10.8	12.1	13.4	14.7	16.0	17.3	18.6	19.9	22.4	25.0	27.6	30.2	32.8	35.4	38.0	40.6
2.5	12.3	13.6	15.0	16.2	17.6	18.8	20.2	21.4	24.0	26.6	29.2	31.8	34.4	37.0	39.6	42.2
3	14.3	15.6	16.9	18.2	19.6	20.8	22.2	23.4	26.0	28.6	31.2	33.8	36.4	39.0	41.6	44.2
3.5	15.9	17.2	18.5	19.8	21.1	22.4	23.7	25.0	27.6	30.2	32.7	35.3	37.9	40.5	43.1	45.7
4	17.4	18.7	20.1	21.3	22.7	23.9	25.3	26.5	29.1	31.7	34.3	36.9	39.5	42.1	44.7	47.3
4.5	19.0	20.3	21.6	22.9	24.3	25.5	26.9	28.1	30.7	33.3	35.9	38.5	41.1	43.7	46.3	48.9
5	20.8	22.1	23.4	24.7	26.0	27.3	28.7	29.9	32.5	35.1	37.7	40.3	42.9	45.5	48.0	50.6
6	24.1	25.4	26.7	28.0	29.4	30.6	32.0	33.2	35.8	38.4	41.0	43.6	46.2	48.8	51.4	54.0
8	30.4	31.7	33.0	34.3	35.7	36.9	38.3	39.5	42.1	44.7	47.3	49.9	52.5	55.1	57.7	60.3
10	37.1	38.4	39.7	41.0	42.3	43.6	44.9	46.2	48.8	51.4	54.0	56.6	59.1	61.7	64.3	66.9
12	43.4	44.7	46.0	47.3	48.6	49.8	51.2	52.4	55.0	57.6	60.2	62.8	65.4	68.0	70.6	73.2
14	47.3	48.6	49.9	51.2	52.5	53.8	55.2	56.4	59.0	61.6	64.2	66.8	69.4	72.0	74.6	77.2
16	53.6	54.9	56.2	57.5	58.8	60.1	61.4	62.7	65.3	67.8	70.4	73.0	75.6	78.2	80.8	83.4
18	59.9	61.1	62.5	63.7	65.1	66.3	67.7	68.9	71.5	74.1	76.7	79.3	81.9	84.5	87.1	89.7
20	66.1	67.4	68.8	70.0	71.4	72.6	74.0	75.2	77.8	80.4	83.0	85.6	88.2	90.8	93.4	96.0
22	72.4	73.7	75.0	76.3	77.7	78.9	80.3	81.5	84.1	86.7	89.3	91.9	94.5	97.1	99.7	102.3
24	78.7	80.0	81.3	82.6	84.0	85.2	86.6	87.8	90.4	93.0	95.6	98.2	100.8	103.4	106.0	108.6
26	85.0	86.3	87.6	88.9	90.2	91.5	92.9	94.1	96.7	99.3	101.9	104.5	107.1	109.7	112.3	114.8
28	91.3	92.6	93.9	95.2	96.5	97.8	99.1	100.4	103.0	105.5	108.1	110.7	113.3	115.9	118.5	121.1
30	97.6	98.8	100.2	101.4	102.8	104.0	105.4	106.6	109.2	111.8	114.4	117.0	119.6	122.2	124.8	127.4
32	103.8	105.1	106.5	107.7	109.1	110.3	111.7	112.9	115.5	118.1	120.7	123.3	125.9	128.5	131.1	133.7
34	110.1	111.4	112.7	114.0	115.4	116.6	118.0	119.2	121.8	124.4	127.0	129.6	132.2	134.8	137.4	140.0
36	116.4	117.7	119.0	120.3	121.7	122.9	124.3	125.5	128.1	130.7	133.3	135.9	138.5	141.1	143.7	146.3
38	122.7	124.0	125.3	126.6	127.9	129.2	130.6	131.8	134.4	137.0	139.6	142.2	144.8	147.4	150.0	152.5
40	129.0	130.3	131.6	132.9	134.2	135.5	136.8	138.1	140.7	143.2	145.8	148.4	151.0	153.6	156.2	158.8
42	135.3	136.5	137.9	139.1	140.5	141.7	143.1	144.3	146.9	149.5	152.1	154.7	157.3	159.9	162.5	165.1
44	141.5	142.8	144.2	145.4	146.8	148.0	149.4	150.6	153.2	155.8	158.4	161.0	163.6	166.2	168.8	171.4
46	147.8	149.1	150.4	151.7	153.1	154.3	155.7	156.9	159.5	162.1	164.7	167.3	169.9	172.5	175.1	177.7
48	154.1	155.4	156.7	158.0	159.4	160.6	162.0	163.2	165.8	168.4	171.0	173.6	176.2	178.8	181.4	184.0

NOTES:

Areas shaded in grey indicate a finished diameter less than 3". Depending on equipment, rolling metal to a finished diameter less than 3" may be problematic. Contact Aspen Aerogels for recommended solutions.

All cut lengths are based on a 2" overlap and do not include for safety edge. Additional amounts required for larger overlap of safety should be added.

All measurements at left should be verified with a test piece.

Contact Aspen Aerogels for additional sizes.

**Cryogel® Z Miter Cut Chart (mm)**

Cryogel Z Thickness															
NPS (mm)	10 mm			20 mm			30 mm			40 mm			50 mm		
	Heel (mm)	Gores	Throat (mm)	Heel (mm)	Gores	Throat (mm)	Heel (mm)	Gores	Throat (mm)	Heel (mm)	Gores	Throat (mm)	Heel (mm)	Gores	Throat (mm)
100	86.2	4	33.5	90.1	4	29.6	94.1	4	25.6	98.0	4	21.7	101.9	4	17.8
125	106.5	4	43.1	110.4	4	39.2	114.3	4	35.3	118.3	4	31.4	122.2	4	27.4
150	84.5	6	35.2	87.1	6	32.6	89.7	6	30.0	92.3	6	27.3	95.0	6	24.7
200	111.1	6	48.5	113.7	6	45.9	116.3	6	43.3	118.9	6	40.6	121.6	6	38.0
250	103.6	8	46.0	105.5	8	44.1	107.5	8	42.1	109.5	8	40.1	111.4	8	38.2
300	123.5	8	56.0	125.5	8	54.1	127.5	8	52.1	129.4	8	50.1	131.4	8	48.2
350	113.3	10	54.3	114.9	10	52.7	116.4	10	51.1	118.0	10	49.6	119.6	10	48.0
400	129.2	10	62.3	130.8	10	60.7	132.4	10	59.1	134.0	10	57.6	135.5	10	56.0
450	121.0	12	58.5	122.3	12	57.2	123.6	12	55.9	124.9	12	54.6	126.2	12	53.3
500	134.3	12	65.2	135.6	12	63.9	136.9	12	62.6	138.2	12	61.3	139.5	12	60.0
550	126.5	14	61.6	127.6	14	60.5	128.8	14	59.3	129.9	14	58.2	131.0	14	57.1
600	137.9	14	67.3	139.0	14	66.2	140.2	14	65.0	141.3	14	63.9	142.4	14	62.8
650	149.3	14	73.0	150.4	14	71.9	151.6	14	70.7	152.7	14	69.6	153.8	14	68.5
700	140.6	16	68.8	141.6	16	67.9	142.6	16	66.9	143.6	16	65.9	144.6	16	64.9
750	150.6	16	73.8	151.6	16	72.8	152.6	16	71.9	153.5	16	70.9	154.5	16	69.9
800	142.7	18	70.1	143.6	18	69.2	144.5	18	68.3	145.4	18	67.4	146.2	18	66.6
850	151.6	18	74.5	152.5	18	73.6	153.3	18	72.7	154.2	18	71.9	155.1	18	71.0
900	144.4	20	71.0	145.2	20	70.2	146.0	20	69.5	146.8	20	68.7	147.6	20	67.9
950	152.4	20	75.0	153.2	20	74.2	154.0	20	73.5	154.8	20	72.7	155.5	20	71.9
1000	160.4	20	79.0	161.2	20	78.2	161.9	20	77.4	162.7	20	76.7	163.5	20	75.9
1050	168.4	20	83.0	169.1	20	82.2	169.9	20	81.4	170.7	20	80.6	171.5	20	79.9
1100	176.3	20	87.0	177.1	20	86.2	177.9	20	85.4	178.7	20	84.6	179.5	20	83.8
1150	184.3	20	91.0	185.1	20	90.2	185.9	20	89.4	186.7	20	88.6	187.5	20	87.8
1200	192.3	20	95.0	193.1	20	94.2	193.9	20	93.4	194.7	20	92.6	195.4	20	91.8

NOTES:

All measurements above should be verified with a test piece.

Contact Aspen Aerogels for additional sizes.

**Cryogel® Z Miter Cut Chart (mm) cont'd.**

Cryogel Z Thickness															
NPS (mm)	60 mm			70 mm			80 mm			90 mm			100 mm		
	Heel (mm)	Gores	Throat (mm)	Heel (mm)	Gores	Throat (mm)	Heel (mm)	Gores	Throat (mm)	Heel (mm)	Gores	Throat (mm)	Heel (mm)	Gores	Throat (mm)
100	86.2	4	13.8	109.8	4	9.9	113.7	4	6.0	117.6	4	2.1	121.6	4	-1.9
125	126.1	4	23.5	130.0	4	19.6	134.0	4	15.6	137.9	4	11.7	141.8	4	7.8
150	97.6	6	22.1	100.2	6	19.5	102.8	6	16.9	105.4	6	14.3	108.1	6	11.6
200	124.2	6	35.4	126.8	6	32.8	129.4	6	30.2	132.0	6	27.6	134.7	6	24.9
250	113.4	8	36.2	115.4	8	34.3	117.3	8	32.3	119.3	8	30.3	121.3	8	28.4
300	133.3	8	46.2	135.3	8	44.2	137.3	8	42.3	139.2	8	40.3	141.2	8	38.3
350	121.1	10	46.4	122.7	10	44.9	124.3	10	43.3	125.9	10	41.7	127.4	10	40.1
400	137.1	10	54.4	138.7	10	52.8	140.2	10	51.3	141.8	10	49.7	143.4	10	48.1
450	127.5	12	52.0	128.9	12	50.7	130.2	12	49.4	131.5	12	48.1	132.8	12	46.8
500	140.8	12	58.6	142.2	12	57.3	143.5	12	56.0	144.8	12	54.7	146.1	12	53.4
550	132.1	14	56.0	133.2	14	54.8	134.4	14	53.7	135.5	14	52.6	136.6	14	51.5
600	143.5	14	61.7	144.6	14	60.5	145.8	14	59.4	146.9	14	58.3	148.0	14	57.2
650	154.9	14	67.4	156.0	14	66.2	157.2	14	65.1	158.3	14	64.0	159.4	14	62.9
700	145.5	16	63.9	146.5	16	62.9	147.5	16	62.0	148.5	16	61.0	149.5	16	60.0
750	155.5	16	68.9	156.5	16	67.9	157.5	16	67.0	158.5	16	66.0	159.4	16	65.0
800	147.1	18	65.7	148.0	18	64.8	148.8	18	63.9	149.7	18	63.1	150.6	18	62.2
850	156.0	18	70.1	156.8	18	69.3	157.7	18	68.4	158.6	18	67.5	159.5	18	66.6
900	148.3	20	67.1	149.1	20	66.3	149.9	20	65.5	150.7	20	64.7	151.5	20	64.0
950	156.3	20	71.1	157.1	20	70.3	157.9	20	69.5	158.7	20	68.7	159.5	20	68.0
1000	164.3	20	75.1	165.1	20	74.3	165.9	20	73.5	166.7	20	72.7	167.4	20	71.9
1050	172.3	20	79.1	173.1	20	78.3	173.9	20	77.5	174.6	20	76.7	175.4	20	75.9
1100	180.3	20	83.1	181.1	20	82.3	181.8	20	81.5	182.6	20	80.7	183.4	20	79.9
1150	188.2	20	87.1	189.0	20	86.3	189.8	20	85.5	190.6	20	84.7	191.4	20	83.9
1200	196.2	20	91.0	197.0	20	90.3	197.8	20	89.5	198.6	20	88.7	199.4	20	87.9

NOTES:

All measurements above should be verified with a test piece.

Contact Aspen Aerogels for additional sizes.

**Cryogel<sup>®</sup> Z Miter Cut Chart (inches)**

Cryogel Z Thickness																
NPS (in.)	0.4 in. (10 mm)			0.8 in. (20 mm)			1.2 in. (30 mm)			1.6 in. (40 mm)			2.0 in. (50 mm)			
	Heel (in.)	Gores	Throat (in.)	Heel (in.)	Gores	Throat (in.)	Heel (in.)	Gores	Throat (in.)	Heel (in.)	Gores	Throat (in.)	Heel (in.)	Gores	Throat (in.)	
4	3.4	4	1.3	3.5	4	1.2	3.7	4	1.0	3.9	4	0.9	4.0	4	0.7	
5	4.2	4	1.7	4.3	4	1.5	4.5	4	1.4	4.7	4	1.2	4.8	4	1.1	
6	3.3	6	1.4	3.4	6	1.3	3.5	6	1.2	3.6	6	1.1	3.7	6	1.0	
8	4.4	6	1.9	4.5	6	1.8	4.6	6	1.7	4.7	6	1.6	4.8	6	1.5	
10	4.1	8	1.8	4.2	8	1.7	4.2	8	1.7	4.3	8	1.6	4.4	8	1.5	
12	4.9	8	2.2	4.9	8	2.1	5.0	8	2.1	5.1	8	2.0	5.2	8	1.9	
14	4.5	10	2.1	4.5	10	2.1	4.6	10	2.0	4.6	10	2.0	4.7	10	1.9	
16	5.1	10	2.5	5.2	10	2.4	5.2	10	2.3	5.3	10	2.3	5.3	10	2.2	
18	4.8	12	2.3	4.8	12	2.3	4.9	12	2.2	4.9	12	2.2	5.0	12	2.1	
20	5.3	12	2.6	5.3	12	2.5	5.4	12	2.5	5.4	12	2.4	5.5	12	2.4	
22	5.0	14	2.4	5.0	14	2.4	5.1	14	2.3	5.1	14	2.3	5.2	14	2.2	
24	5.4	14	2.6	5.5	14	2.6	5.5	14	2.6	5.6	14	2.5	5.6	14	2.5	
26	5.9	14	2.9	5.9	14	2.8	6.0	14	2.8	6.0	14	2.7	6.1	14	2.7	
28	5.5	16	2.7	5.6	16	2.7	5.6	16	2.6	5.7	16	2.6	5.7	16	2.6	
30	5.9	16	2.9	6.0	16	2.9	6.0	16	2.8	6.0	16	2.8	6.1	16	2.8	
32	5.6	18	2.8	5.7	18	2.7	5.7	18	2.7	5.7	18	2.7	5.8	18	2.6	
34	6.0	18	2.9	6.0	18	2.9	6.0	18	2.9	6.1	18	2.8	6.1	18	2.8	
36	5.7	20	2.8	5.7	20	2.8	5.7	20	2.7	5.8	20	2.7	5.8	20	2.7	
38	6.0	20	3.0	6.0	20	2.9	6.1	20	2.9	6.1	20	2.9	6.1	20	2.8	
40	6.3	20	3.1	6.3	20	3.1	6.4	20	3.0	6.4	20	3.0	6.4	20	3.0	
42	6.6	20	3.3	6.7	20	3.2	6.7	20	3.2	6.7	20	3.2	6.8	20	3.1	
44	6.9	20	3.4	7.0	20	3.4	7.0	20	3.4	7.0	20	3.3	7.1	20	3.3	
46	7.3	20	3.6	7.3	20	3.6	7.3	20	3.5	7.3	20	3.5	7.4	20	3.5	
48	7.6	20	3.7	7.6	20	3.7	7.6	20	3.7	7.7	20	3.6	7.7	20	3.6	

NOTES:

All measurements above should be verified with a test piece.

Contact Aspen Aerogels for additional sizes.

**Cryogel® Z Miter Cut Chart (inches) cont'd.**

Cryogel Z Thickness																
NPS (in.)	2.4 in. (60 mm)			2.8 in. (70 mm)			3.2 in. (80 mm)			3.6 in. (90 mm)			4.0 in. (100 mm)			
	Heel (in.)	Gores	Throat (in.)	Heel (in.)	Gores	Throat (in.)	Heel (in.)	Gores	Throat (in.)	Heel (in.)	Gores	Throat (in.)	Heel (in.)	Gores	Throat (in.)	
4	3.4	4	0.5	4.3	4	0.4	4.5	4	0.2	4.6	4	0.1	4.8	4	-0.1	
5	5.0	4	0.9	5.1	4	0.8	5.3	4	0.6	5.4	4	0.5	5.6	4	0.3	
6	3.8	6	0.9	3.9	6	0.8	4.0	6	0.7	4.2	6	0.6	4.3	6	0.5	
8	4.9	6	1.4	5.0	6	1.3	5.1	6	1.2	5.2	6	1.1	5.3	6	1.0	
10	4.5	8	1.4	4.5	8	1.3	4.6	8	1.3	4.7	8	1.2	4.8	8	1.1	
12	5.2	8	1.8	5.3	8	1.7	5.4	8	1.7	5.5	8	1.6	5.6	8	1.5	
14	4.8	10	1.8	4.8	10	1.8	4.9	10	1.7	5.0	10	1.6	5.0	10	1.6	
16	5.4	10	2.1	5.5	10	2.1	5.5	10	2.0	5.6	10	2.0	5.6	10	1.9	
18	5.0	12	2.0	5.1	12	2.0	5.1	12	1.9	5.2	12	1.9	5.2	12	1.8	
20	5.5	12	2.3	5.6	12	2.3	5.6	12	2.2	5.7	12	2.2	5.8	12	2.1	
22	5.2	14	2.2	5.2	14	2.2	5.3	14	2.1	5.3	14	2.1	5.4	14	2.0	
24	5.7	14	2.4	5.7	14	2.4	5.7	14	2.3	5.8	14	2.3	5.8	14	2.3	
26	6.1	14	2.7	6.1	14	2.6	6.2	14	2.6	6.2	14	2.5	6.3	14	2.5	
28	5.7	16	2.5	5.8	16	2.5	5.8	16	2.4	5.8	16	2.4	5.9	16	2.4	
30	6.1	16	2.7	6.2	16	2.7	6.2	16	2.6	6.2	16	2.6	6.3	16	2.6	
32	5.8	18	2.6	5.8	18	2.6	5.9	18	2.5	5.9	18	2.5	5.9	18	2.4	
34	6.1	18	2.8	6.2	18	2.7	6.2	18	2.7	6.2	18	2.7	6.3	18	2.6	
36	5.8	20	2.6	5.9	20	2.6	5.9	20	2.6	5.9	20	2.5	6.0	20	2.5	
38	6.2	20	2.8	6.2	20	2.8	6.2	20	2.7	6.2	20	2.7	6.3	20	2.7	
40	6.5	20	3.0	6.5	20	2.9	6.5	20	2.9	6.6	20	2.9	6.6	20	2.8	
42	6.8	20	3.1	6.8	20	3.1	6.8	20	3.1	6.9	20	3.0	6.9	20	3.0	
44	7.1	20	3.3	7.1	20	3.2	7.2	20	3.2	7.2	20	3.2	7.2	20	3.1	
46	7.4	20	3.4	7.4	20	3.4	7.5	20	3.4	7.5	20	3.3	7.5	20	3.3	
48	7.7	20	3.6	7.8	20	3.6	7.8	20	3.5	7.8	20	3.5	7.8	20	3.5	

NOTES:

All measurements above should be verified with a test piece.

Contact Aspen Aerogels for additional sizes.



**Appendix A: Insulation Materials and Accessory Suppliers**
**TABLE 1: INSULATION, FIRE-PROTECTION AND ACCESSORY MATERIALS AND SUPPLIERS**

System Component	Insulation System Material Description	Manufacturer / Brand Names	Applicable Surfaces
<b>Insulation and/or Passive Fire Protection</b>	5 mm (0.2 in) thick Cryogel Z blanket	Aspen Aerogels / Cryogel Z	All
	10 mm (0.4 in) thick Cryogel Z blanket	Aspen Aerogels / Cryogel Z	Piping $\geq$ 100 mm (4 in) NPS; all vessels, and equipment
	V-grooved aerogel blanket	SMC Industries / Cryogel Z V-Groove	Piping <100 mm (4 in) NPS
	Pre-cut elbows	SMC Industries / Precision CNC AA Fitting Covers	All short-radius, long radius, socket-weld, and swept elbows
<b>Joint Sealing Tape</b>	Foil-faced butyl tape, 50-100 mm (2-4 in) wide	Covalence Adhesives / Polyken 360-17	For application temps at or above 15°C (59°F), or when using cold weather surface primer
		Denso / Denso Butyl 35 Tape	
		Venture Tape / Mastiktape 1580	
		Isoltema / Crio-Seal Tape 19/15	
		Isoltema / Crio-Seal Tape Lite 19/15	
Or equivalent			
	Foil / Polyester Laminate, 50-100 mm (2-4 in) wide	Venture Tape / 1555CW	For application temps at or above -18°C (0°F)
<b>Optional Sheet Mastics</b>	1.2 mm (0.050 in) foil-faced butyl sheet	Polyguard / Insulrap 50	All
		Foster Products / C.I. Wrap 50	
		Isoltema / Crio-Seal Vapour Barrier 12/25/12	
		Or equivalent	
<b>Cold Weather Surface Primer</b>	SBR	Foster Products / 8200 adhesive	For use when low ambient temperatures reduce surface tack on tapes and sheet mastics
		Foster Products / 85-45 FOS-STIK	
<b>Vapor Stop Sealant</b>	Hypalon rubber vapor barrier coating	Foster Products / Monolar II 60-38/39	For process temperatures down to -40°C (-40°F)
		Foster Products / Monolar 60-95/96	
	Cryogenic vapor barrier coating	Foster Products / 90-66	For process temperatures down to -196°C (-320°F)
		Foster Products / Cryolar 90-61	

**Appendix A: Insulation Materials and Accessory Suppliers cont'd.**

**TABLE 1: INSULATION, FIRE-PROTECTION AND ACCESSORY MATERIALS AND SUPPLIERS**

<b>System Component</b>	<b>Insulation System Material Description</b>	<b>Manufacturer / Brand Names</b>	<b>Applicable Surfaces</b>
<b>Vapor Barrier Mastics</b>	Hypalon rubber vapor barrier mastic	Foster Products / Monolar II 60-38/39	All
<b>Membrane Reinforcement</b>	Glass or polyester open-weave cloth	Foster Products / Mast-a-Fab	All
		Or equivalent	
<b>Elbow Covers</b>	Pressed aluminum jacket covers sized for aerogel thicknesses	Ideal Products / AA WeatherJacs	All short- and long-radius elbows up to 900 mm (36 in)
<b>Spray Adhesive</b>	Halogen-free spray adhesive (can or bulk)	Foster Products / 85 45 FOS-STIK	All
		3M / 78-Spray	
		Nashua / 357SA	
		Or equivalent	
<b>Strapping Tape</b>	12 mm (1/2 in) wide fiber-reinforced packing tape	Scotch Reinforced Strapping Tape 862	All
		Or equivalent	
<b>Mechanical Standoff Layer</b>	HDPE membrane, 20mm (0.75 in) dimples	Cosella Dorken / Delta - MS 20	All
		Or equivalent non-insulating mechanical standoff	

For specialized training or recommendations regarding our application procedures, call 508-691-1111, visit [info.aerogel.com/contact](http://info.aerogel.com/contact), or scan below with mobile device QR reader.

